

Dual-Flo

The Dual-Flo unit cooler is designed for use in walk-in coolers and freezers to increase storage space. Its extra-low profile and two-way discharge permits mounting above aisle areas without sacrificing either headroom or proper air circulation. Walls are thus free for maximum utilization of shelving. It is ideal for convenience stores, supermarkets, restaurants and other low-ceiling-type installations.



Two-Way Discharge

Air Defrost Models – 6,400 through 25,000 BTUH @ 10 Degree T.D.

Electric Defrost Models – 4,800 through 21,800 BTUH @ 10 Degree T.D.

Now available with EC Motors
High Efficiency / High Reliability



Performance and Electrical Data

Air Defrost Models

Model Number	BTUH @ +25°F S.T.		CFM	SP* MOTOR AMPS		PSC* MOTOR AMPS		EC* MOTOR AMPS		
	10°T.D.	15°T.D.		115/1	208-230/1	115/1	208-230/1	115/1	208-230/1	
8 FPI	AMC38-75	7,500	11,250	1,455	3.6	1.4	1.10	.54	1.2	0.6
	AMC38-88	8,800	13,200	1,305	3.6	1.4	1.10	.54	1.2	0.6
	AMC38-98	9,800	14,700	1,200	3.6	1.4	1.10	.54	1.2	0.6
	AMC48-112	11,200	16,800	2,120	4.8	1.8	1.44	.75	1.6	0.8
	AMC48-130	13,000	19,500	1,920	4.8	1.8	1.44	.72	1.6	0.8
	AMC48-10	15,000	22,500	1,760	4.8	1.8	1.44	.75	1.6	0.8
	AMC58-162	16,200	24,300	2,320	6.0	2.3	1.80	.90	2.0	1.0
	AMC48-210	21,000	31,500	1,820	4.8	1.8	1.44	.72	1.6	0.8
	AMC58-230	23,000	34,500	2,650	6.0	2.3	1.80	.90	2.0	1.0
	AMC68-250	25,000	37,500	2,970	7.2	2.8	2.16	1.1	2.4	1.2
6 FPI	AMC36-64	6,400	9,600	1,560	3.6	1.4	1.10	.54	1.2	0.6
	AMC36-82	8,200	12,300	1,425	3.6	1.4	1.10	.54	1.2	0.6
	AMC3 6-93	9,300	13,950	1,305	3.6	1.4	1.10	.54	1.2	0.6
	AMC46-100	10,000	15,000	2,160	4.8	1.8	1.44	.72	1.6	.08
	AMC46-123	12,300	18,450	2,040	4.8	1.8	1.44	.72	1.6	0.8
	AMC46-140	14,000	21,000	1,920	4.8	1.8	1.44	.72	1.6	0.8
	AMC56-157	15,700	23,500	2,360	6.0	2.3	1.80	.90	2.0	1.0
	AMC46-190	19,000	28,500	1,940	4.8	1.8	1.44	.72	1.6	0.8
	AMC56-208	20,800	31,200	2,850	6.0	2.3	1.80	.90	2.0	1.0
	AMC66-232	23,200	34,800	2,970	7.2	2.8	2.16	1.1	2.4	1.2

SP* = Shaded Pole motor(s) PSC* = Permanent Split Capacitor(s) EC* = Electronically Commutated Motor(s)
Standard voltage for AMC models is 115/1/60

Electric Defrost Models

Model Number	BTUH @ 10°T.D.		CFM	SP* MOTOR AMPS 208-230/1	PSC* MOTOR AMPS 208-230/1	EC* MOTOR AMPS 208-230/1	DEFROST WATTS	DEFROST AMPS		
	-20°S.T.	+20°S.T.						208-230/1	460/1	
6 FPI	ELC36-53	5,300	6,360	1440	1.4	N/A	0.6	2070	9.0	4.5
	ELC36-62	6,200	7,440	1290	1.4	N/A	0.6	2070	9.0	4.5
	ELC36-69	6,900	8,200	1245	1.4	N/A	0.6	2070	9.0	4.5
	ELC46-77	7,700	9,240	2075	1.8	N/A	0.8	2990	13.0	6.5
	ELC46-90	9,000	10,800	1860	1.8	N/A	0.8	2990	13.0	6.5
	ELC46-100	10,000	12,000	1740	1.8	N/A	0.8	2990	13.0	6.5
	ELC56-125	12,500	15,000	2160	2.3	N/A	1.0	3910	17.0	8.5
	ELC46-140	14,000	16,800	1820	1.8	N/A	0.8	3910	17.0	8.5
	ELC56-160	16,000	19,200	2550	2.3	N/A	1.0	3910	17.0	8.5
	ELC66-218	21,800	23,200	3000	2.8	N/A	1.2	3910	17.0	8.5
4 FPI	ELC34-48	4,800	5,760	1500	1.4	N/A	0.6	2070	9.0	4.5
	ELC34-58	5,800	6,960	1395	1.4	N/A	0.6	2070	9.0	4.5
	ELC34-65	6,500	7,800	1350	1.4	N/A	0.6	2070	9.0	4.5
	ELC44-72	7,200	8,640	2120	1.8	N/A	0.8	2990	13.0	6.5
	ELC44-84	8,400	10,080	1980	1.8	N/A	0.8	2990	13.0	6.5
	ELC44-95	9,500	11,400	1900	1.8	N/A	0.8	2990	13.0	6.5
	ELC54-115	11,500	13,800	2280	2.3	N/A	1.0	3910	17.0	8.5
	ELC44-128	12,800	15,360	1940	1.8	N/A	0.8	3910	17.0	8.5
	ELC54-145	14,500	17,400	2650	2.3	N/A	1.0	3910	17.0	8.5
	ELC64-173	17,300	20,760	3080	2.8	N/A	1.2	3940	17.0	8.5

SP* = Shaded Pole motor(s) PSC* = Permanent Split Capacitor(s) EC* = Electronically Commutated Motor(s)
230V/1 motors are suitable for 208V operation. Standard voltage for ELC models is 208-230/1/60

Physical Data

Air Defrost Models

	Model Number	DIMENSIONS (IN)				TXV TYPE	CONNECTIONS(IN)		SHIP WT. (LBS)	
		L	W	H	A		B	LIQ. (ODS)		SUCT. (ODS)
8 FPI	AMC38-75	58-1/2	28-3/4	8	24	24	EXT	1/2	5/8	95
	AMC38-88	58-1/2	28-3/4	8	24	24	EXT	1/2	5/8	100
	AMC38-98	58-1/2	28-3/4	8	24	24	EXT	1/2	5/8	105
	AMC48-112	82-1/2	28-3/4	8-3/4	36	36	EXT	1/2	7/8	125
	AMC48-130	82-1/2	28-3/4	8-3/4	36	36	EXT	1/2	7/8	130
	AMC48-150	82-1/2	28-3/4	8-3/4	36	36	EXT	1/2	7/8	135
	AMC58-162	106-1/2	28-3/4	8-3/4	48	48	EXT	1/2	7/8	150
	AMC48-210	106-1/2	28-3/4	10-1/4	48	48	EXT	1/2	7/8	155
	AMC58-230	106-1/2	28-3/4	10-1/4	48	48	EXT	1/2	7/8	165
	AMC68-250	106-1/2	28-3/4	10-1/4	48	48	EXT	1/2	1-1/8	185
6 FPI	AMC36-64	58-1/2	28-3/4	8	24	24	EXT	1/2	5/8	90
	AMC36-82	58-1/2	28-3/4	8	24	24	EXT	1/2	5/8	95
	AMC36-93	58-1/2	28-3/4	8	24	24	EXT	1/2	5/8	100
	AMC46-100	82-1/2	28-3/4	8-3/4	36	36	EXT	1/2	7/8	120
	AMC46-123	82-1/2	28-3/4	8-3/4	36	36	EXT	1/2	7/8	125
	AMC46-140	82-1/2	28-3/4	8-3/4	36	36	EXT	1/2	7/8	130
	AMC56-157	106-1/2	28-3/4	8-3/4	48	48	EXT	1/2	7/8	145
	AMC46-190	106-1/2	28-3/4	10-1/4	48	48	EXT	1/2	7/8	150
	AMC56-208	106-1/2	28-3/4	10-1/4	48	48	EXT	1/2	7/8	160
	AMC66-232	106-1/2	28-3/4	10-1/4	48	48	EXT	1/2	1-1/8	180

Electric Defrost Models

	Model Number	DIMENSIONS (IN)				TXV TYPE	CONNECTIONS(IN)		SHIP WT. (LBS)	
		L	W	H	A		B	LIQ. (ODS)		SUCT. (ODS)
6 FPI	ELC36-53	58-1/2	28-3/4	8	24	24	EXT	1/2	5/8	95
	ELC36-62	58-1/2	28-3/4	8	24	24	EXT	1/2	5/8	100
	ELC36-69	58-1/2	28-3/4	8	24	24	EXT	1/2	5/8	105
	ELC46-77	82-1/2	28-3/4	8-3/4	36	36	EXT	1/2	7/8	125
	ELC46-90	82-1/2	28-3/4	8-3/4	36	36	EXT	1/2	7/8	130
	ELC46-100	82-1/2	28-3/4	8-3/4	36	36	EXT	1/2	7/8	135
	ELC56-125	106-1/2	28-3/4	8-3/4	48	48	EXT	1/2	7/8	150
	ELC46-140	106-1/2	28-3/4	10-1/4	48	48	EXT	1/2	7/8	155
	ELC56-160	106-1/2	28-3/4	10-1/4	48	48	EXT	1/2	7/8	165
	ELC66-218	106-1/2	28-3/4	10-1/4	48	48	EXT	1/2	1-1/8	185
4 FPI	ELC34-48	58-1/2	28-3/4	8	24	24	EXT	1/2	5/8	90
	ELC34-58	58-1/2	28-3/4	8	24	24	EXT	1/2	5/8	95
	ELC34-65	58-1/2	28-3/4	8	24	24	EXT	1/2	5/8	100
	ELC44-72	82-1/2	28-3/4	8-3/4	36	36	EXT	1/2	7/8	120
	ELC44-84	82-1/2	28-3/4	8-3/4	36	36	EXT	1/2	7/8	125
	ELC44-95	82-1/2	28-3/4	8-3/4	36	36	EXT	1/2	7/8	130
	ELC54-115	106-1/2	28-3/4	8-3/4	48	48	EXT	1/2	7/8	145
	ELC44-128	106-1/2	28-3/4	10-1/4	48	48	EXT	1/2	7/8	150
	ELC54-145	106-1/2	28-3/4	10-1/4	48	48	EXT	1/2	7/8	160
	ELC64-173	106-1/2	28-3/4	10-1/4	48	48	EXT	1/2	1-1/8	180

Nomenclature

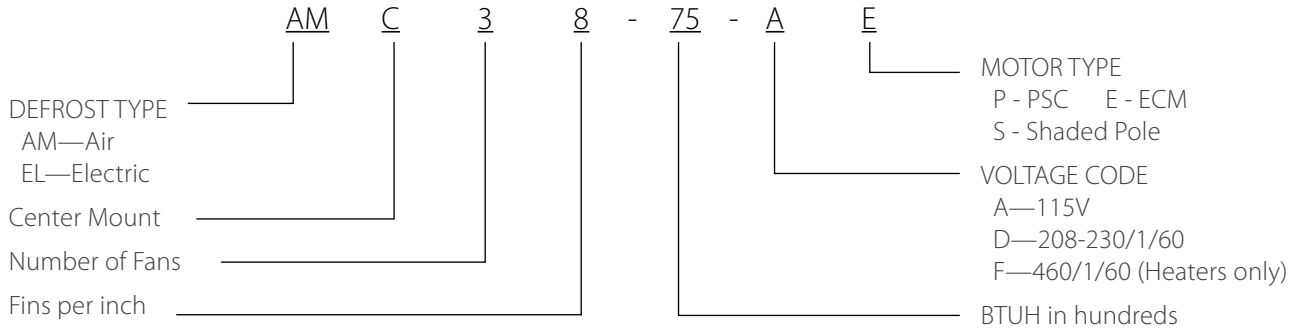

Dimensional Drawing

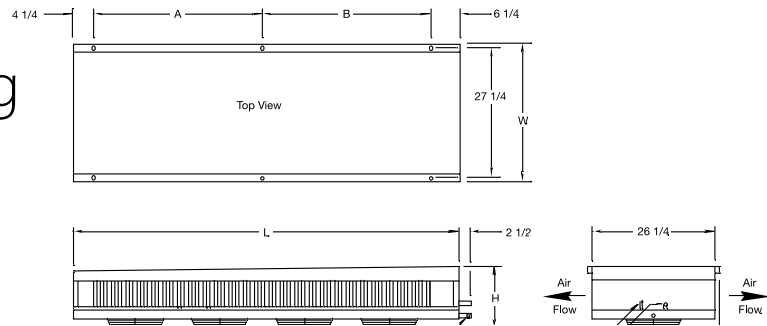

Energy Savings Analysis

16 Watt, PSC and EC (SP = Shaded Pole motor, PSC= Permanent Split Capacitor Motor, EC= Electronically Commutated Motor)

Motor Change	Standard Motor Power Watts/Mtr	"Change to" Motor Power Watts/Mtr	Power Reduction Watts/Mtr	Run Time Hrs/Day	Motor Energy Savings kWh/Yr	Motor Energy Savings \$/Yr	Reduced Box Load MBTU/Yr	Cond. Unit EER	Cond. Unit Energy Savings kWh/Yr	Cond. Unit Energy Savings \$/Yr	Total Savings \$/Yr	Pay back Yrs
SP to PSC	75	51	24	22	193	19	658	5.2	126	13	32	1.0
SP to EC	75	35	40	22	321	32	1,096	5.2	211	21	53	2.0
PSC to EC	51	35	16	22	128	13	438	5.2	84	8	21	3.4

Subtract 6% from total savings for medium temperature 24 run hours per day.

Features

- Flush-to-the-ceiling mounting - Providing extra storage room
- Two-way air flow for even air circulation and consistent temperature
- Hinged drain pan for easy service access and cleaning
- Quiet operation - Ideal for use in rooms with glass display doors



SOLUTIONS

RDI provides many of the operational solutions from Manitowoc Foodservice, a global company dedicated to bringing value to foodservice operators by equipping them with highly individualized real-world answers that enhance menus, service, profits and efficiency.

To learn how Manitowoc Foodservice and its leading brands can equip you, visit our global web site at www.manitowocfoodservice.com then find the regional or local resources available to you.