

FC-S Filter Cartridges

Deliver premium quality drinking water for ice and steam applications



APPLICATIONS

Ice
Steam & Combi Ovens
Coffee

FEATURES AND BENEFITS

Increased capacity for extended reduction of chemical and mechanical contaminants.

Balanced cartridge for optimum performance in varying water qualities.

Integrated beaded phosphate with levels specifically selected for greater life and scale inhibition.

Compatible with Insurice, Insurice PF, QC71, QL2, QL3B and QL3 Heads.

New Fibredyne II media with AgION® antimicrobial protection inhibits any potential bacterial growth.

Reduces chlorine taste and odor and other offensive contaminants that can adversely affect the taste of beverages.

Improves the taste of fountain beverages and helps retain the drink's carbonation.

Submicron technology reduces dirt and particles as small as 1/2 micron in size, and reduces health contaminants such as *Cryptosporidium* and *Giardia* cysts.

Protects drink system seals, pump, tubing and small orifices from clogging, corrosion and abrasive wear.

Sanitary cartridge replacement is simple, quick and clean. Internal filter parts are never exposed to handling or contamination.

NSF Certified under NSF/ANSI Standards 42 and 53.

OPERATIONAL TIPS

Change cartridges on a regular 6 month preventative maintenance program.

Change cartridges when capacity is reached or when pressure falls below 10 psi.

Always flush the filter cartridge at time of installation and cartridge change.



4FC-S Replacement Cartridge 1 PK: EV9692-31
7FC-S Replacement Cartridge 1 PK: EV9692-71

SPECIFICATIONS

	4FC-S	7FC-S
Overall Dimensions:	14.5"H x 3.25" D (36.8 cm x 8.3 cm)	20.75" H x 3.25" D (52.7 x 8.3 cm)
Service Flow Rate:	2.5 gpm (9.5 lpm)	2.5 gpm (9.5 lpm)
Rated Capacity:	15,000 Gallons (56,781 L)	25,000 gallons (94,635 L)
Pressure Requirements:	10 – 125 psi (0.7 – 8.6 bar), non-shock	10 – 125 psi (0.7 – 8.6 bar), non-shock
Temperature:	35 – 100°F (2 – 38°C)	35 – 100°F (2 – 38°C)
Electrical Connection:	None	None

FC-S Filter Cartridges

4FC-S EV9692-31 • 7FC-S EV9692-71

INSTALLATION TIPS

Install vertically so cartridge hangs down.

Allow 2½" clearance below the cartridge for easy cartridge replacement.

Flush cartridge by running water through system for five minutes at full flow.

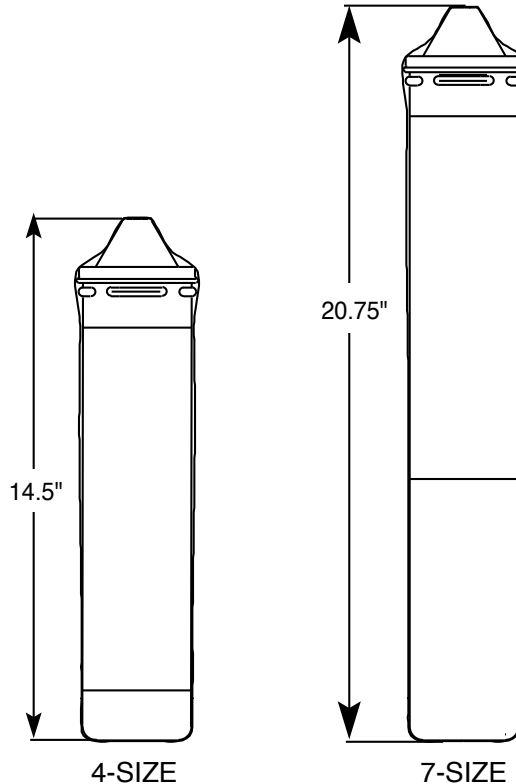

Everpure water treatment systems (excluding replaceable elements) are covered by a limited warranty against defects in material and workmanship for a period of five years after date of purchase. Everpure replaceable elements (filter cartridges and water treatment cartridges) are covered by a limited warranty against defects in material and workmanship for a period of one year after date of purchase. See printed warranty for details. Everpure will provide a copy of the warranty upon request.

Everpure reserves the right to update specifications, change prices, or make substitutions without notice.

The contaminants or other substances removed or reduced by this drinking water system are not necessarily in your water. Do not use with water that is microbiologically unsafe or of unknown quality without adequate disinfection before or after the system. Systems certified for cyst reduction may be used with disinfected water that may contain filterable cysts.



System Tested and Certified by NSF International against NSF/ANSI Standard 42 and 53 for the reduction of:

Std. No. 42-

Aesthetic effects
Bacteriostatic Effects

Chemical Reduction
Taste & Odor
Chlorine

Mechanical Filtration
Nominal Particulate Class I

Std. No. 53-

Health effects
Mechanical Filtration
Turbidity
Cyst

EV9692-31-71 AP1111

EVERPURE®

WATER YOU CAN TRUST®

Visit our website at www.everpure.com

Everpure-SHURflo India
Green Boulevard, B-9/A, 7th Floor -
Tower B Sector 62, Noida - 201301
TEL: 91.120.419.9444
FAX: 91.120.419.9400
EMAIL: indiacustomer@pentair.com

Everpure-SHURflo Japan Inc.
Hashimoto MN Bldg. 7F
3-25-1 Hashimoto, Midori-ku
Sagamihara-Shi Kanagawa 252-0143
JAPAN
TEL: 81.(0)42.775.3011
FAX: 81.(0)42.775.3015
EMAIL: info@everpure.co.jp

Everpure-SHURflo China
21F Cloud 9 Plaza, No 1118,
Shanghai, 200052
CHINA
TEL: 86.21.3211.4588
FAX: 86.21.3211.4580
EMAIL: China.Water@Pentair.com

Pentair Filtration Solutions, LLC
World Headquarters-Everpure/SHURflo
North and South America Sales
1040 Muirfield Dr.
Hanover Park, Illinois 60133
USA
TEL: 800.942.1153 (US only)
TEL: 630.307.3000
FAX: 630.307.3030
EMAIL: cseverpure@pentair.com

Everpure-SHURflo Australia
2 Redwood Drive
Notting Hill
Victoria, 3168
AUSTRALIA
TEL: 011.61.39.574.4000
FAX: 011.61.39.562.7237
EMAIL: au.everpure@pentair.com

Everpure-SHURflo Southeast Asia
18 Boon Lay Way
#04-110/111
TradeHub 21, 609966
SINGAPORE
TEL: 65.6795.2213
FAX: 65.6795.2219
EMAIL: cseverpure@pentair.com

Everpure-SHURflo Europe
Pentair Water Belgium bvba
Industriepark Wolfstee
Toekomstlaan
30 B-2200 Herentals, BELGIUM
TEL: +32.(0).14.283.500
FAX: +32.(0).14.283.505
EMAIL: sales@everpure-europe.com